



12th IEA Heat Pump Conference 2017



Comparison of energy performance of simulated and measured heat pump systems in existing multi-family residential buildings

Tuomo Niemelä^{a,b,*}, Risto Kosonen^b, Juha Jokisalo^b

^a Granlund Consulting Oy, Malminkaari 21, FI-00701 Helsinki, Finland

^b Aalto University, School of Engineering, Otakaari 4, PO Box 14100, FI-00076 Aalto, Finland

Abstract

More advanced and versatile simulation tools are required to reliably simulate the dynamic operation and performance of modern heat pump and other renewable energy production systems as a part of dynamic energy simulation of buildings to meet the requirements of the recast EPBD. The paper presents a comparison of energy performance between simulated and real installed heat pump systems with measured field-data. The simulated heat pump systems were modelled accurately and in detail by using the new IDA Indoor Climate and Energy (IDA ICE) Early Stage Building Optimization (ESBO) Plant model, calibrated by using real manufacturer product data and simulated as a part of dynamic energy simulation of two case study buildings located in cold Finnish climate. The studied heat pump systems included an air-to-water heat pump system (case building 1) and a ground source heat pump system (case building 2) installed in multi-family residential buildings. The error margins of the simulated systems were -9.6...-13.7 % with the A2WHP system and +1.0 % with the GSHP system, showing good consistency and accuracy with the real installed systems. Both the simulation results and the measured performance data of the case studies indicated that the installation principle of the heat pump system has a relatively significant impact on the operation and on the energy efficiency of the system. The results of the study demonstrated that the studied dynamic simulation tool is an accurate and reliable method to simulate the energy performance of the modern variable condensing heat pump systems operating in cold climate conditions.

© 2017 Stichting HPC 2017.

Selection and/or peer-review under responsibility of the organizers of the 12th IEA Heat Pump Conference 2017.

Keywords: dynamic energy simulation; optimization; energy performance; cost-effectiveness; heat pump system; residential building

* Corresponding author. Tel.: +358 40 662 1274; fax: -.
E-mail address: tuomo.niemela@granlund.fi.

Nomenclature			
A-F	constants calculated from rating conditions and from the type of the heat pump, -;	COP	coefficient of performance, -;
COP _{Rat}	COP in rated conditions, $EER_{Rat}+1$;	c_{ctr}	input control signal [0:1], -;
DCW	domestic cold water	DHW	domestic hot water
EER	energy efficiency ratio (=COP-1), -;	EER _F	energy efficiency ratio at full load, -;
EER _{Rat}	$COP_{Rat}-1 =$ given EER at rated conditions;	G	part load exponent, -;
P_{comp}	compressor power, W;	P_{compF}	full load compressor power, W;
$P_{compRat}$	compressor power in rated conditions, W;	PLF	part load fraction, -;
PLR	part load ratio, -;	Q_{cond}	condenser power, W;
Q_{condF}	full load condenser power, W;	$Q_{condRat}$	heating capacity in rated conditions, W;
Q_{evap}	evaporator power, W;	Q_{evapF}	full load evaporator power, W;
$Q_{evapRat}$	cooling capacity in rated conditions, W;	SPF	seasonal performance factor, -;
T_{cIn}	condenser side inlet temperature, °C;	T_{cond}	condensation temperature, °C
$T_{condRat}$	calculated condensation temperature in rated conditions, °C;	T_{cOut}	condenser side outlet temperature, °C;
T_{eIn}	evaporator side inlet temperature, °C;	T_{eOut}	evaporator side outlet temperature, °C;
T_{evap}	evaporation temperature, °C;	$T_{evapRat}$	calculated evaporation temperature in rated conditions, °C;
ΔT_c	condenser side logarithmic (mean) temperature difference, °C;	ΔT_e	evaporator side logarithmic (mean) temperature difference, °C;

1. Introduction

The dynamic energy and indoor climate condition simulations are used to determine cost-effective and energy efficient overall solutions also having excellent indoor environment conditions. The accuracy and reliability of the currently used modern energy simulation tools have been tested and validated during the last decade and multiple tools have become proven and widely used simulation tools on the market. However, since the implementation of the recast EPBD-directive (2010/31/EU), more features are required from the simulation tools to accurately and reliably simulate the on-site renewable energy production systems, such as heat pump and solar-based energy production systems, preferably as a part of dynamic energy simulation of buildings. This sets increasing demands for the versatility and performance requirements of simulation tools, as the energy systems of nearly zero-energy buildings (nZEBs) and modern low energy buildings are becoming more complex. In order to design functional and cost-effective HVAC and energy production systems, suitable simulation methods, which can take the simulation of on-site renewable energy sources (RES) into account are needed. Furthermore, the performance and accuracy of the used methods must be validated first to determine if they can be reliably used as a designing and dimensioning tool of modern and developing renewable energy production systems.

When the simulation of on-site RES is discussed, the more simplifying assumptions are used to estimate the performance of the systems in dynamic energy simulations, the more unreliable and inaccurate simulation results are obtained according to several recent studies [1-3]. The dynamic simulation of the net heating and cooling demands of buildings is relatively simple, but an accurate simulation of the modern heat pump systems operating with variable condensing features is difficult to perform as a part of the dynamic energy simulation and often the energy performance of the heat pump systems is estimated by using simplifying Coefficient of Performance (COP)- or Seasonal Performance Factor (SPF)-based performance values to predict the annual energy efficiency of the systems. Multiple popularly used dynamic simulation software, e.g. IDA ICE EnergyPlus and TRNSYS, are capable of simulating different renewable energy production systems in addition to the more conventional

net energy demand simulations. While the aforementioned programs are commonly used, the performance and reliability of the programs still requires further testing and validation according to general conclusion, especially in the simulation of heat pump systems with variable condensing operation.

The objective of this study was to test the performance and functionality of a fully dynamic simulation method and to validate and assess the performance of the method to simulate the energy performance of different heat pump systems as a part of dynamic energy simulation of buildings. The study is a spin-off project of the previous project conducted by Niemelä et al. 2016 [3], where the performance of different heat pump systems was initially tested and a calibration method to improve the accuracy of the energy simulations regarding the heat pump systems was developed. The studied energy simulation tool was IDA ICE (IDA Indoor Climate and Energy, versions 4.7 and 4.7.1) and the recent implementation of the Early Stage Building Optimization (ESBO) Plant model included in the IDA ICE software. The ESBO Plant model is developed to simulate the RES installed on-site, including all commonly used heat pump systems. The study included testing the performance of an air-to-water heat pump (A2WHP) system and a ground source heat pump (GSHP) system. In this study, the performance of the calibrated heat pump systems is compared to the performance of real installed systems with measured performance data. The study aims to determine, if the calibrated heat pump models can be accurately and reliably used in the dimensioning and simulation of real dynamic heat pump systems operating with variable condensing features in cold climate conditions.

2. Methods

2.1. Modelling of heat pump systems in IDA ICE

A short description and a summary of the basic principles used to model the heat pump systems in IDA ICE are presented in this chapter. In general, IDA ICE is a fully dynamic simulation software which can be used for detailed modelling of multi-zone buildings. The accuracy and reliability of IDA ICE in basic energy simulations including different HVAC systems, internal and solar loads, outdoor and indoor climate conditions and simultaneous simulation of both mass flows and heat transfer has been validated in several previous studies [4-8]. The ESBO Plant model currently operating as a part of IDA ICE is used to model the operation and performance of different heat pump and renewable energy production systems. The heat pump models of the ESBO Plant can also be calibrated according to real manufacturer heat pump unit product data by using a suitable calibration methodology. The operation of heat pump systems is modelled in IDA ICE by EQUA Simulation AB, the developer of the software, using the following Equations (1-2):

$$Q_{cond} = P_{comp} \cdot COP \quad (1)$$

$$Q_{evap} = P_{comp} \cdot EER \quad (2)$$

Furthermore, to model the performance of the modern heat pump systems in variable operating conditions, the operation principle of the simulation model is divided into partial load properties and full load properties. To simulate both the partial and full load performances accurately, calibration parameters A-G are used. The calibration parameters are determined from the (standardized) rating conditions of the real heat pump systems. The full and partial load operations are modelled by Equations (3-13), where Equations (9-10) are used to calculate the logarithmic temperature differences of both the condenser and evaporator:

$$P_{compF} = D \cdot \exp(E \cdot T_{evap} + F \cdot T_{cond}) \quad (3)$$

$$Q_{evapF} = A \cdot \exp(B \cdot T_{evap} + C \cdot T_{cond}) \quad (4)$$

$$P_{comp} = c_{ctr} \cdot P_{compF} \quad (5)$$

$$PLF = 1 + G \cdot \ln(PLR) = \frac{EER}{EER_F} \quad (6)$$

$$PLR = \frac{Q_{evap}}{Q_{evapF}} \quad (7)$$

$$COP = EER + 1 \quad (8)$$

$$T_{cond} = \frac{T_{cIn} - T_{cOut} \cdot \exp\left(\frac{T_{cOut} - T_{cIn}}{\Delta T_c}\right)}{1 - \exp\left(\frac{T_{cOut} - T_{cIn}}{\Delta T_c}\right)} \quad (9)$$

$$T_{evap} = \frac{T_{eIn} - T_{eOut} \cdot \exp\left(\frac{T_{eOut} - T_{eIn}}{\Delta T_e}\right)}{1 - \exp\left(\frac{T_{eOut} - T_{eIn}}{\Delta T_e}\right)} \quad (10)$$

$$D = P_{compRat} \cdot \exp(-E \cdot T_{evapRat} - F \cdot T_{condRat}) \quad (11)$$

$$A = P_{compRat} \cdot \exp(-B \cdot T_{evapRat} - C \cdot T_{condRat}) \cdot EER_{Rat} \quad (12)$$

$$P_{compRat} = \frac{Q_{condRat}}{COP_{Rat}} \quad (13)$$

The Equations and their specific functions are described in more detail in a recent study [3]. Furthermore, experimental data based on field measurements of real heat pump units equipped with various compressor types was also used to derive Equation (6). Eq. (6) is an approximated method derived by Jan-Erik Nowacki and EQUA Simulation Ab to simulate the partial load operation of heat pump systems equipped with partial load capacity control.

2.2. Calibration of the simulated heat pump models

The calibrated heat pump models that were used in the dynamic energy simulations of the studied case buildings were the Carrier 61WG-090 brine-to-water heat pump unit and the Mitsubishi Electric CAHV-P500YA-HPB air-to-water heat pump unit. Both of the studied heat pump units are equipped with scroll-type compressors and the Mitsubishi unit is also equipped with an inverter-type capacity control. The Carrier 61WG-090 heat pump unit is operating with an on/off-based control. As the objective of the calibration is to minimize the error margin of annual energy performance between the simulated heat pump models and the corresponding real heat pump units, the definition of the seasonal performance factor (SPF) is used. The main target is to calibrate the energy performance of the simulation model to correspond to the real performance data of the actual heat pump system in all operating conditions. The heat pump models were calibrated according to the

manufacturer performance data of different rating conditions. Furthermore, the heat pump model setup of IDA ICE, including the main connections and features, is shown in Fig. 1 for reference. A detailed description of the main components, e.g. the heat storage tank model, and the operation of the heat pump system is discussed in more detail in previous studies [2,3]. The actual calibration process is conducted by using a simulation-based optimization analysis.

The main results of the calibration process are shown in Figs. 2 and 3. The performance of the default heat pump models, where the manufacturer product data is used but the simulated heat pump model is not calibrated, included in the IDA ICE ESBO Plant is also shown in Figs. 2 and 3 for comparison. According to the results of the calibration, too optimistic energy simulation results would be achieved by using the uncalibrated default heat pump models. More discussion about the results and the calibration methodology is presented in references [2,3].

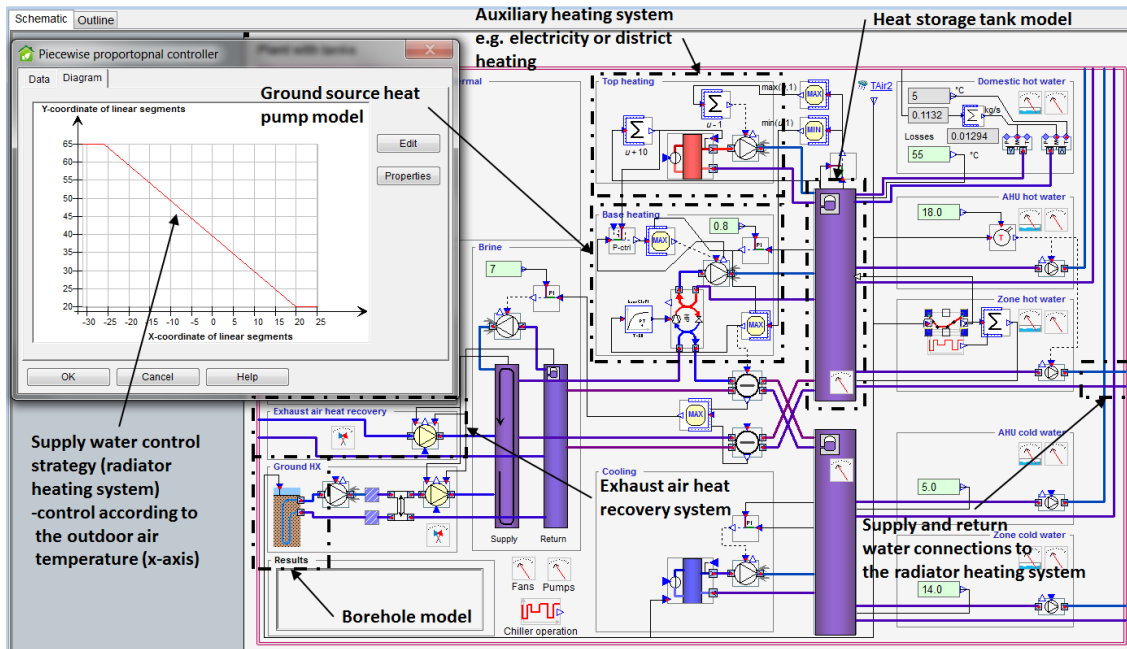

Fig. 1. The heat pump model setup of the ESBO Plant with the main features highlighted.

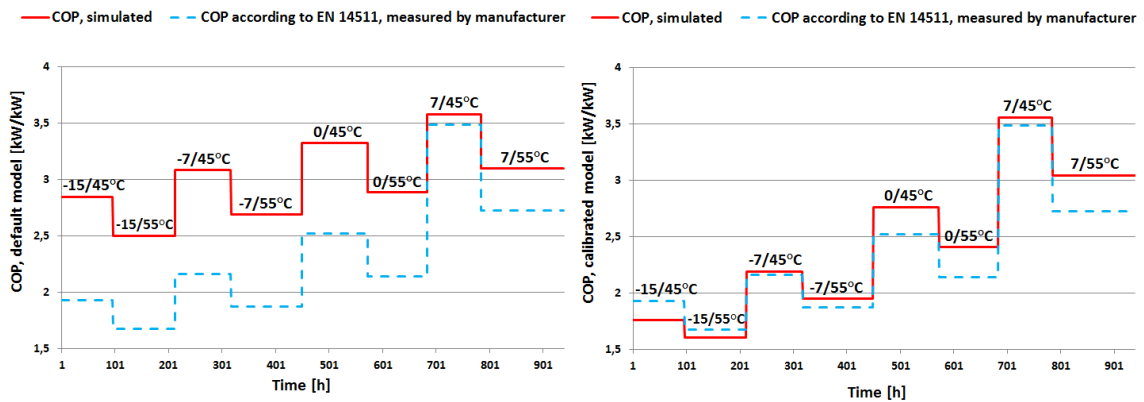

Fig. 2. The performance of the default A2WHP model (left) and the performance of the best calibrated A2WHP model (right).

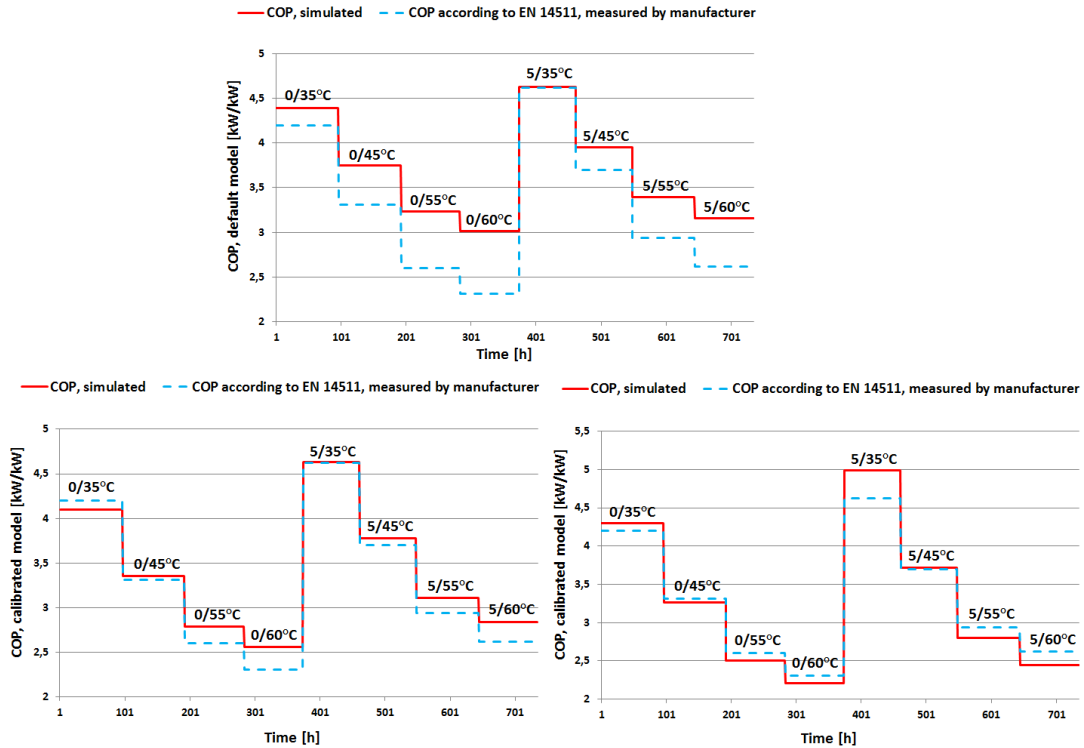

Fig. 3. The performance of the default GSHP model (top) and the performance of the best two calibrated GSHP models (bottom left/right).

3. Case studies

3.1. Case building 1, A2WHP system

The actual heat pump system (Mitsubishi CAHV-P500YA-HPB) was installed in the building complex in 2014. The studied building complex is called As Oy Aurinkoranta and it consists of three individual row houses, which were originally heated by light fuel oil. The studied houses are located in Hanko, Finland. After the installation of the A2WHP system, the heat pump system has been used as the main heating system of the houses and the original light fuel oil heating system has remained as the auxiliary heating system of the houses during the coldest periods of the heating season. The houses were modelled according to their individual features in IDA ICE and the energy consumption of the simulation model was fine-tuned to correspond to the original measured energy consumption data of the houses before the heat pump system was installed. The measured and normalized energy consumption data of the houses is shown in Table 1 and the main geometry details of the constructed IDA ICE simulation model are shown in Fig. 4, respectively. As the studied houses are located in the city of Hanko, the energy consumption data is normalized to correspond to the Helsinki-Vantaa test reference year 2012 (TRY2012) weather data according to Table 1 [9].

The specific heat content of the Finnish light fuel oil is 10 kWh/dm³ [10]. The heating degree day (S17) data of Hanko was used to normalize the actual energy consumptions of the studied houses. The heating degree days are updated and maintained by the Finnish Meteorological Institute [11]. The total domestic hot water consumption of the houses was approximately 2 m³/day, which equals to 730 m³/year. The temperature of the DHW must be at least 55 °C, but below 65 °C in Finland. The houses are equipped with mechanical exhaust air

ventilation systems without any heat recovery system. The external structures of the houses are typical 1970's structures. The external walls of the houses are brick-structured with a U-value of 0.35 W/(m² K) for a reference.

The studied heat pump system was installed in the houses in early 2014 so year 2015 was the first full year when the heat pump system operated as the main heating system of the houses. Therefore, the original energy simulation model was calibrated according to the energy consumption data of 2012 and the operation and energy performance of the simulated heat pump system was compared to the energy consumption data of 2015. The dimensioning temperatures of the original hydronic radiator heating system of the houses were 80/60 °C and the studied heat pump system heated both the radiator and the DHW heating systems. The reference oil price shown in Table 1 is the average price of 2015, as the price of fuel oil has decreased significantly over the last three years.

Table 1. The measured and normalized energy consumption data of the studied houses in 2012, 2014 and 2015.

Year and heating degree day S17 number	Oil consumption [dm ³ /a]	Electricity consumption of the heat pump system [kWh/a]	Normalized energy consumption to Helsinki-Vantaa TRY2012, the average annual heating degree day number S17 is 3 952 Kd	Reference price of oil [€/dm ³]	Reference price of electricity [€/MWh]	Total energy cost [€/a]
2012 (3 797)	30 590	0	31 660 dm ³ /a (oil), 0 MWh/a (electricity)	0.8	110	25 330
2014 (3 464)	10 112	60 146	11 240 dm ³ /a (oil), 65.6 MWh/a (electricity)	0.8	110	16 210
2015 (3 118)	5 712	74 173	6 670 dm ³ /a (oil), 88.3 MWh/a (electricity)	0.8	110	15 050

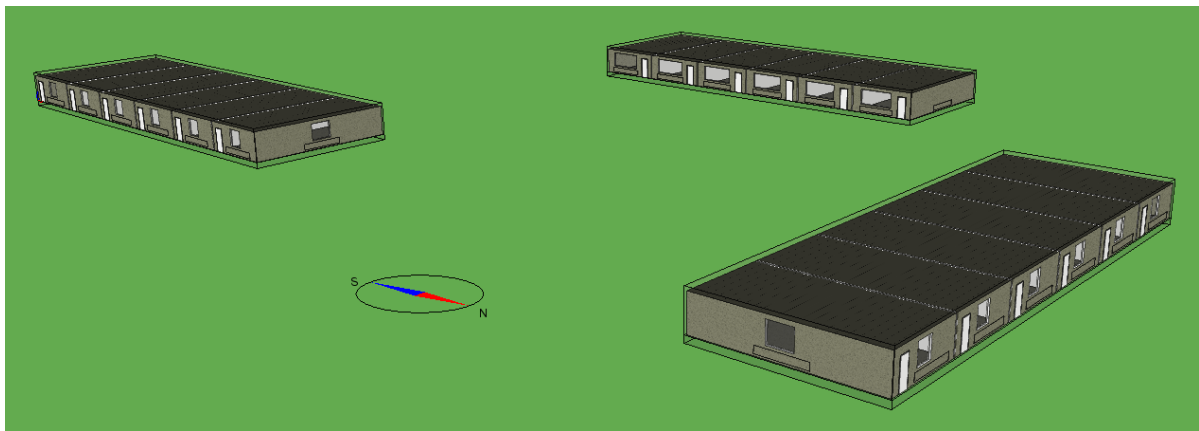

Fig. 4. The main geometry of the studied row houses modelled in the IDA ICE simulation environment.

After the calibration and fine-tuning of the simulation model shown in Fig. 4, the energy simulations were conducted using the calibrated Mitsubishi CAHV-P500YA-HPB product data. The nominal power output of the heat pump system is 63.2 kW under 7/45 °C (inlet air temperature 7 °C and outlet water temperature 45 °C) rating conditions. As the heat pump unit is equipped with the inverter-type control, the heating capacity of the unit can be adjusted from 10 kW to 63 kW according to the real time heating demand of the building. The studied heat

pump system is equipped with an exchange valve and both the radiator and the DHW heating systems are heated separately.

The results of the dynamic energy simulations before and after the installation of the studied A2WHP system, with the reference cost factors shown in Table 1 also taken into account, were:

- Before the installation:
 - light fuel oil consumption: 31 610 dm³/a;
 - electricity consumption of the heat pump system: 0 MWh/a;
 - total energy cost according to the reference energy prices (Table 1): 28 450 €/a;
- After the installation:
 - light fuel oil consumption: 3 932 dm³/a;
 - electricity consumption of the heat pump system: 95.0 MWh/a;
 - total energy cost according to the reference energy prices (Table 1): 13 600 €/a;
- Total annual energy cost difference to the measured data: -1 450 €/a, which is approximately -9.6 %.
- The simulated and measured SPF-values of the systems were: 2.63 (simulated), 2.72 (measured).
 - The measurement inaccuracy is approximately ±1 % according to the system supplier.

3.2. Case building 2, GSHP system

The GSHP system case study was conducted similarly as the A2WHP system case study described in chapter 3.1. The simulation model was constructed according to the features of the corresponding real building and the energy simulation model was calibrated according to the measured energy consumption data of the case building. The case building is a multi-family apartment building called As Oy Hämeenlinnan Kaivokatu 12 and it is located in Hämeenlinna, Finland. The heat pump system was installed in the building in December 2014, so year 2015 was the first full year of operation with the heat pump system being used as the main heating system of the building. The original main heating system of the building was district heating, but the district heating system was demolished during the installation of the heat pump system and the new auxiliary heating system of the building was changed to direct electricity. The dimensioning temperatures of the original radiator heating system of the building were 70/50 °C, but the radiator heating system was carefully balanced after the installation of the heat pump system to operate at 65/50 °C dimensioning temperatures. The new dimensioning temperature level was determined to be sufficient after the balancing process, as the original hydronic radiators were a little over-dimensioned compared to the actual heating demand of the building, which is a typical situation in many of the existing Finnish multi-family apartment buildings built in the 1960's and 1970's.

The total measured domestic hot water consumption of the building was approximately 3.85 m³/day, which equals to approximately 1 405 m³/year. The original building is equipped with a mechanical exhaust air ventilation system without any heat recovery system. The external structures of the building are typical late 1970's large concrete panel apartment building structures. For a reference, the U-value of the external walls is 0.29 W/(m² K) according to the Finnish building regulations, which came into force in 1978.

The GSHP system installed in the building was the Carrier 61WG-090 brine-to-water heat pump unit. The brine circulation system consists of five boreholes that were installed in the plot of the building with each borehole being 260 meters deep (active depth). Furthermore, an exhaust air heat recovery system was installed along with the installation of the GSHP system to collect the heat energy content of the exhaust air. The exhaust air heat recovery system was connected to the borehole brine circulation system, resulting in a hybrid GSHP system including both boreholes and exhaust air heat recovery used in the brine circulation system. The exhaust air heat recovery system can be simulated in combination with the boreholes in the IDA ICE simulation software, as shown in Fig. 1. The measured and normalized energy consumption data of the building is shown in Table 2 and the main geometry details of the constructed IDA ICE simulation model are shown in Fig. 5, respectively. DH and HP stand for District Heating and Heat Pump in Table 2.

Table 2. The measured and normalized energy consumption data of the studied apartment building in 2013 and 2015.

Year and heating degree day S17 number	District heating consumption [kWh/a]	Electricity consumption of the heat pump system [kWh/a]	Normalized energy consumption to Helsinki-Vantaa TRY2012, the average annual heating degree day number S17 is 3 952 Kd	Reference price of DH energy [€/MWh]	Reference price of electricity [€/MWh]	Total energy cost [€/a]
2013 (4 023)	335 470	0	331.0 MWh/a (district heating), 0 MWh/a (electricity)	64.4	110	21 320
2015 (3 662)	0	96 516 (HP), 4 210 (aux. elec.)	102.2 MWh/a (heat pump system), 4.5 MWh/a (auxiliary elec. heating)	64.4	110	11 740

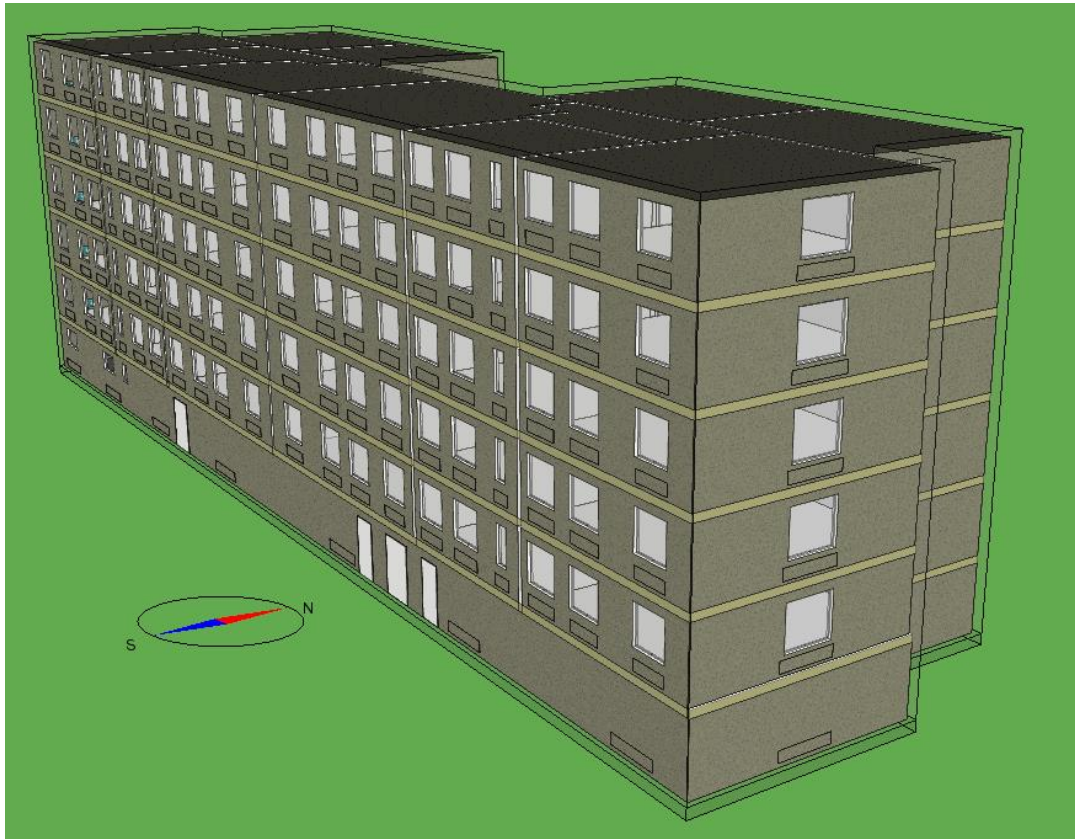

Fig. 5. The main geometry of the studied apartment building modelled in the IDA ICE simulation environment.

After the calibration and fine-tuning of the simulation model shown in Fig. 5, the energy simulations were conducted using the calibrated Carrier 61WG-090 product data. The nominal power output of the heat pump system is 94.6 kW in 5/45 °C (inlet brine temperature 5 °C and outlet water temperature 45 °C) rating conditions. The heat pump unit is equipped with two individual compressor units (47 kW per compressor) and with the on-off-type control. Therefore, there are three capacity control steps in the system, 0 kW, 47 kW and 95 kW, which are selected according to the heating demand of the building. The studied heat pump system is equipped with an exchange valve and both the radiator and the DHW heating systems are heated separately.

The results of the dynamic energy simulations before and after the installation of the studied GSHP system, with the reference cost factors shown in Table 2 also taken into account, were:

- Before the installation:
 - district heating energy consumption: 332.7 MWh/a;
 - electricity consumption of the heat pump and auxiliary heating systems: 0 MWh/a;
 - total energy cost according to the reference energy prices (Table 2): 21 430 €/a;
- After the installation:
 - district heating energy consumption: 0 MWh/a;
 - electricity consumption of the heat pump system: 101.5 MWh/a;
 - electricity consumption of the auxiliary heating system (direct electricity): 6.3 MWh/a;
 - total energy cost according to the reference energy prices (Table 2): 11 860 €/a;
- Total annual energy cost difference to the measured data: +120 €/a, which is approximately +1.0 %.
- The simulated and measured SPF-values of the systems were: 3.11 (simulated), 3.19 (measured).
 - The measurement inaccuracy is approximately ± 1 % according to the system supplier.

4. Discussion

The performance of the simulated GSHP system was almost identical with the performance of the corresponding real heat pump system. The simulated GSHP system used approximately 700 kWh/a less electricity, but the electricity consumption of the auxiliary electrical heating system was approximately 1 800 kWh/a higher, respectively. The average error margin between the simulated and the real heat pump systems was approximately +1.0 %, when both the annual delivered energy consumption and the annual energy costs are discussed. The installation principle of the real GSHP system was determined to be energy efficient and recommendable. The GSHP system was installed using two individual heat storage tanks, where one of the tanks was used for DHW heating (high temperature storage tank) and the other was used for heating of the radiator system. The GSHP unit was equipped with an exchange valve and both the DHW and the radiator heating systems were heated separately according to the heating demand of the systems. While there are even more energy efficient installation principles for heating of the DHW with a heat pump system, the energy efficiency of the studied installation principle is high and the installation costs of the used implementation are also lower than the installation costs of a more complex and sophisticated DHW heating implementation.

The difference between the simulated and measured performance data of the A2WHP system was significantly higher compared to the difference in the GSHP case study, when the annual energy costs are discussed. The real A2WHP system seemed to consume a little less electrical energy than the simulated heat pump system, but the system consumed more oil, respectively. In the audit, it was noted that the installation method of the real A2WHP system could have been more energy efficient. The system was installed so that the DHW was heated by both the oil boiler and the heat pump system. However, due to the implementation and the connections of the DHW heat storage tank, the oil boiler heated the DHW a lot more than it would need to, if a more energy efficient connection method was used. In the installed system, the temperature of the DHW storage tank is so high throughout the year that the A2WHP system is not able to effectively preheat the DHW with maximum efficiency before the oil boiler is used. In the ideal situation, the A2WHP system would preheat both the radiator heating system water and the DHW with maximum capacity and the oil boiler would be used as an auxiliary heating system only after the full capacity of the heat pump system is insufficient.

As the original connection principle of the studied A2WHP system was not as efficient as it could be, a recommendation for a more energy efficient installation principle of the system was determined, where the A2WHP is heating both the DHW and the radiator heating system by using an exchange valve and two separate heat storage tanks, which also ensure longer operating times for the heat pump unit. The recommended installation principle of the A2WHP systems equipped with variable condensing operation is shown in Fig. 6.

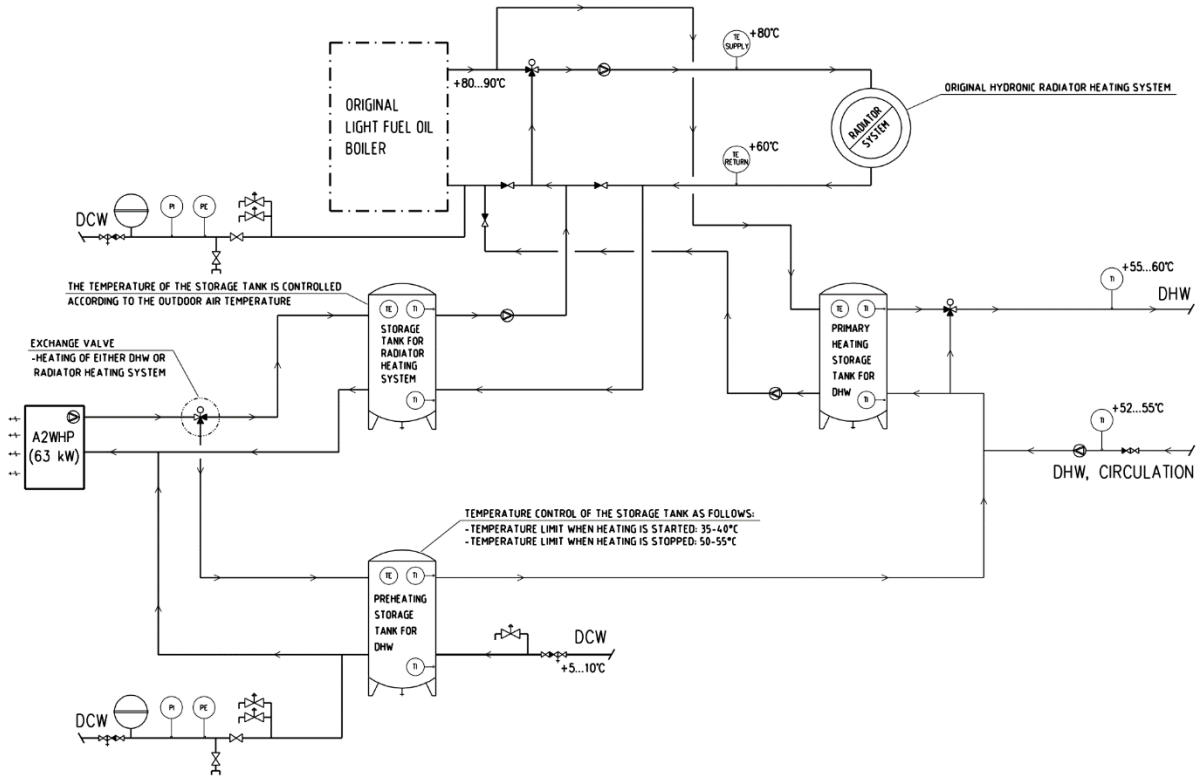

Fig. 6. The recommended installation principle of the A2WHP systems equipped with variable condensing operation.

5. Conclusions

The performance and accuracy of the selected dynamic simulation method was assessed in two individual multi-family residential case buildings. The studied heat pump systems included an air-to-water heat pump system and a ground source heat pump system. The results of the dynamic energy simulations showed good agreement with the measured performance data of the corresponding real heat pump systems in both of the studied case buildings. Especially the simulation results of the GSHP system were extremely close to the measured performance data of the real system. When the performance of the simulated heat pump systems is assessed from the annual energy costs perspective, the error margins were -9.6 % for the studied A2WHP system, with the simulation results delivering lower annual energy costs, and +1.0 % for the studied GSHP system, with the simulation results delivering higher annual energy costs. When the performance is assessed from the annual delivered energy consumptions perspective, the corresponding error margins were -13.3 % (simulation model delivering lower energy consumption) for the A2WHP system and +1.0 % (simulation model delivering higher energy consumption) for the GSHP system, respectively.

The overall error margin of the simulated A2WHP system was significantly larger than the error margin of the simulated GSHP system. In the audit, it was noted that the original oil boiler was used too often compared to the actual heating demand of the auxiliary heating system and the A2WHP system was not used in the heating of the DHW as much as it could be used. As a result of the audit, a more energy efficient installation principle was determined for the studied A2WHP system. The studied GSHP system showed almost identical performance between the simulated and the real installed heat pump system.

Typically, the financial saving potential of a heat pump system is the most important individual factor in the decision making process of multi-family residential building owners. Therefore, it is important to develop accurate and usable simulation methods to estimate the realistic economical saving potentials of different heat pump systems operating in different climate conditions. The results of the study demonstrated that the studied dynamic simulation tool is an accurate and reliable method to simulate the energy performance of the modern variable condensing heat pump systems operating in cold climate conditions. According to the study, the studied simulation method is a recommendable platform to be used in the dynamic simulations of different heat pump systems as a part of dynamic energy simulation of buildings. However, a sufficient calibration of the default heat pump models is recommended before the models are used in real case studies.

Acknowledgements

This study was an individual research project conducted by Granlund Consulting Oy and Aalto University during 06/2015-05/2016. The authors take this opportunity to thank Senera Oy, Carrier Oy, Scanoffice Oy and Laroc Oy for their important and valuable contribution to this study. The authors wish to thank Timo-Mikael Sivula at Senera Oy and Jouko Tidenberg at Laroc Oy for their valuable help, support and cooperation during this study.

References

- [1] Häkämies, S., Hirvonen, J., Jokisalo, J., Knuuti, A., Kosonen, R., Niemelä, T., Paiho, S., Pulakka, S., 2015. Heat pumps in energy and cost efficient nearly zero energy buildings in Finland, project HP4NZEB, VTT Technical Research Centre of Finland Ltd, Espoo, Finland, 2015.
- [2] Niemelä, T., 2015. Cost Optimal Renovation Solutions in the 1960s Apartment Buildings, Master's Thesis, Aalto University, School of Engineering, Department of Energy Technology, HVAC 2015, Espoo, Finland.
- [3] Niemelä T, Vuolle M, Kosonen R, Jokisalo J, Salmi W, Nisula M., 2016. Dynamic simulation methods of heat pump systems as a part of dynamic energy simulation of buildings, In: Proceedings of BSO2016: 3th conference of international building performance simulation association England, Newcastle, England, September 12–14, 2016. Paper number 1146.
- [4] Sahlin, P., 1996. Modelling and Simulation Methods for Modular Continuous Systems in Buildings. Doctoral Dissertation, Department of Building Sciences, Division of Building Services Engineering, Royal Institute of Technology 1996, Stockholm, Sweden. ISSN 0284-141X.
- [5] Björnsell, N., Bring, A., Eriksson, L., Grozman, P., Lindgren, M., Sahlin, P., Shapovalov, A., Vuolle, M., 1999. IDA indoor climate and energy, Proceedings of the IBPSA Building Simulation '99 conference, Kyoto, Japan.
- [6] Achermann, M. and Zweifel, G., 2003. RADTEST – Radiant heating and cooling test cases, Subtask C, A Report of IEA Task 22, Building Energy Analysis Tools, 2003.
- [7] Loutzenhiser, P., Manz, H., Maxwell, G., 2007. Empirical Validations of Shading / Daylighting / load Interactions in building energy simulation tools, A Report for the International energy Agency SHC Task 34, ECBCS Annex 43 Project C, 2007.
- [8] Travesi, J., Maxwell, G., Klaassen, C., Holtz, M., 2001. Empirical validation of Iowa energy resource station building energy analysis simulation models, IEA Task 22, Subtask A, 2001.
- [9] Kalamees, T., Jylhä, K., Tietäväinen, H., Jokisalo, J., Ilomets, S., Hyvönen, R., Saku, S., 2012. Development of weighting factors for climate variables for selecting the energy reference year according to the EN ISO 15927-4 standard, Energy and Buildings 47 (2012), pp. 53–60.
- [10] National Building Code of Finland, 2007. Part D5, Calculation of power and energy needs for heating of buildings, guidelines 2007. Ministry of the Environment, Helsinki, Finland.
- [11] The Finnish Meteorological Institute, 2016. The annual S17 degree day numbers of Finnish cities. Available online at: <http://ilmatieteenlaitos.fi/lammitystarveluvut> (in Finnish).